

BRONZE IMPURITY COLLECTING FILTER

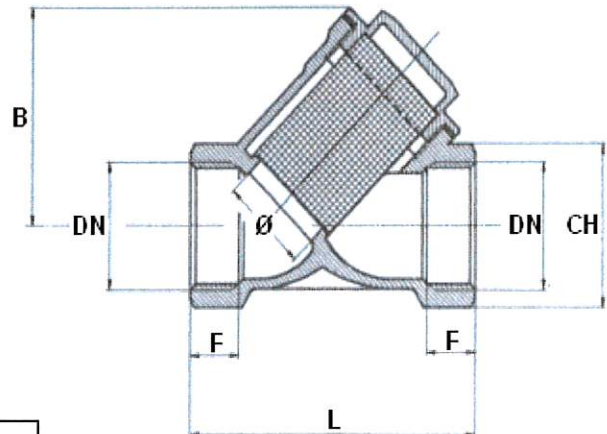

STANDARD VALVE FEATURES

Working temperature : MIN. -20°C / MAX. +120°C
 Max pressure : 16 bar (10 bar)
 Threaded ends : ISO 228/1
 Sandblasted finishing

Parts	Material	Q.ty
Body	G-CuSnZn5 Pb5 UNI 7013-72	1
Filter	Inox AISI 304	1
Plug	EN12164-CW614N	1
Gasket	Fiber (absent asbestos)	1

DN	3/8"	1/2"	3/4"	1"	1"1/4	1"1/2	2"	2"1/2	3"	4"
Ø	12	15	20	25	32	40	50	65	78	98
L	55	59	69	82	98.5	109	131	151	172	219
B	40	44	50.5	60	73	80	98	114	130	170
F	10	11	12	14	17	17	19	21	21	24
CH	22	26	32	38	48	52	66	82	96	124
PN	16					10				

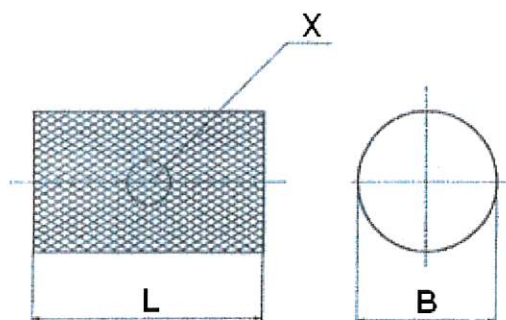

(DETAIL X)

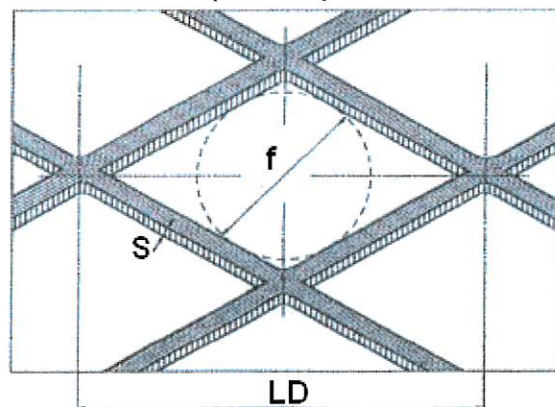

Filter technical data					
DN	L	B	LD	s	f
3/8"	29.5	18	1.5	0.15	0.40
1/2"	32	19	1.5	0.15	0.40
3/4"	39	25	1.5	0.15	0.40
1"	46	30	1.5	0.15	0.40
1"1/4	55	38	2	0.20	0.47
1"1/2	61.5	43	2	0.20	0.47
2"	75.5	58	2	0.20	0.53
2"1/2	90	66	2.5	0.25	0.53
3"	105	77	2.5	0.25	0.53
4"	139	100	2.5	0.25	0.53



Section

We don't assume the responsibility if you use products which are not consistent with the material used for the construction of our valves.

To be used as a guide only, IDROSFER reserve the right to change these data without notice.



INSTRUCTIONS

IST. DATA SHEET - 029 ING

Rev. 0

MAINTENANCE

Before take a valve apart, make sure that the pipe are not under pressure.

Every six months check the valve visually to verify there are no defects that may cause problems when using it and, if the case, replace it. Before acting on the valve make sure that the pipes are not under pressure. We are not responsible in case of tampering of our valves without our authorization, in this case the warranty expires.

WASTE DISPOSAL

After replacement of the valve, it must be disposed according to the laws (about the waste disposal) of the Country of destination.

The waste (disused valve) can also be identified as recyclable material.

LIST OF INCOMPATIBLE SUBSTANCES

Many chemical substances react in a dangerous way when they come in touch with others.

Please find below a list of the main incompatible substances, by way of a non-limiting example.

Acetylene	with copper (piping), halogens, silver, mercury and their compounds
Acetone	with concentrated mixtures of sulphuric and nitric acid
Acetic acid	with chromic acid, nitric acid, hydroxyls, ethylene glycol, perchloric acid, peroxides and permanganates
Chromic acid	with acetic acid, naphthalene, camphor, alcohol, glycerol, turpentine and inflammable fluids
Nitric acid	with acetic, chromic and cyanogenic acid, aniline, carbon, hydrogen sulphide, fluids, gases and substances that are promptly nitrated
Oxalic acid	with silver and mercury
Perchloric acid	with acetic anhydride, bismuth and its alloys, alcohol, paper, wood, fats and other organic substances
Hydrogen sulphide	with nitric acid and oxidants.
Sulphuric acid	with chlorates, perchlorates, permanganates and water.
Alcohols and Polyols	with nitric acid.
Anhydrous ammonia	with mercury, halogens, calcium hypochlorite and hydrogen fluoride
Ammonium nitrate	with acids, metal powders, sulphur, combustible materials
Aniline	with nitric acid and hydrogen peroxide
Silver	with acetylene, oxalic acid, tartaric acid and ammoniac compounds
Arsenic (materials containing)	with any reducing agent
Azidos	with water.
Chlorine dioxide	with ammonia, methane, phosphine, hydrogen sulphide
Bromine	with ammonia, acetylene, butadiene, butane, hydrogen, sodium carbide, turpentine and
Activated carbon	with all oxidizing agents, calcium hypochlorite
Cyanides	with acids and alkali
Chlorates	with ammonia salts, acids, metal powders, sulphur, finely pulverized organic and flammable compounds and carbon
Chlorine	with ammonia, acetylene, butadiene, petrol and other by-products of oil, hydrogen, sodium carbide, turpentine and finely pulverized metals
Chloroform	with sodium and potassium
Chlorides	with sulphuric acid
Dichloromethane	with sodium and potassium
Chlorine dioxide	with ammonia, methane, phosphine, hydrogen sulphide
Fluorine	with all other chemical substances
(White) phosphorus	with air, oxygen, alkali, reducing agents
Hydrocarbons in general	with fluorine, chlorine, formic acid, chromic acid, sodium peroxide
Hydrogen sulphate	with nitric acid vapours and oxidizing gasses
Iodine	with acetylene and ammonia
Hypochlorite	with acids, activated carbon
Flammable fluids	with ammonium nitrate, chromic acid, hydrogen peroxide, nitric acid, sodium peroxide and halogens
Mercury	with acetylene, fulminic acid, hydrogen
Alkaline metals (e.g. calcium, potassium, sodium)	with water, carbon dioxide, carbon tetrachloride, and other chlorinated hydrocarbons
Ammonium nitrate	with acids, metal powders, flammable fluids, chlorates, nitrates, sulphur and finely pulverized organic substances or flammable compounds
Nitrites and Nitrates	with acids
Nitroparaffin	with inorganic bases, amines
Calcium oxide	with water
Oxygen	with oils, fats, hydrogen, flammable fluids, solids and gasses
Phosphorus pentoxide	with water
Potassium perchlorate	with sulphuric acid and other acids.
Potassium permanganate	with glycerol, ethylene glycol, benzaldehyde and sulphuric acid
Hydrogen peroxide	with chromium, copper, iron, most other metals and their salts, flammable fluids and other combustible materials, aniline and nitromethane
Sodium peroxide	with any oxidizable substance, such as methanol, glacial acetic acid, acetic anhydride, benzaldehyde, carbon disulphide, glycerol, ethyl acetate and furfural.
Potassium	with carbon tetrachloride, carbon dioxide, water, chloroform, dichloromethane
Copper	with acetylene, azide and hydrogen peroxide
Sodium	with carbon tetrachloride, carbon dioxide, water, chloroform, dichloromethane
Sodium azide	with lead, copper and other metals. This compound is usually employed as a preservative, but it forms unstable and explosive compounds with metals
Selenium	with reducing agents
Sulphides	with strong acids
Carbon tetrachloride	Sodium, potassium